

## Warnings

Connect the power supply according to the safety regulations for electrical equipment.

- > Risk of injury
- > Damage to or destruction of the sensor

The supply voltage must not exceed the specified limits. Avoid shocks and impacts to the sensor. Do not bend or cant the sensor rod and the measuring tube.

Do not carry the sensor on the sensor rod.

- > Damage to or destruction of the sensor

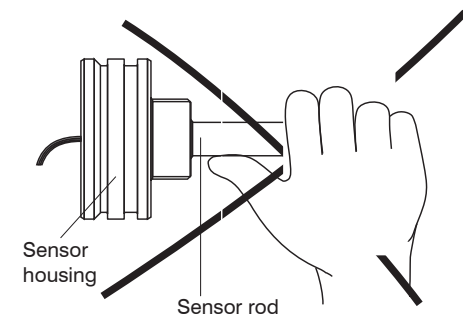

## Notes on CE Marking

The following apply to induSENSOR EDS eddy current long-stroke displacement sensors with current output:

- EU Directive 2014/30/EU
- EU Directive 2011/65/EU

The sensor satisfies the requirements if the guidelines in the operating instructions are maintained in installation and operation.

## Proper Environment

- Protection class:
  - Front side: 450 bar
  - Rear side: 1 IP40
- Temperature range:
  - Storage: -40 ... +100 °C (-40 ... +212 °F)
  - Operation: -40 ... +85 °C (-40 ... +185 °F)
- Humidity: 5 - 95 % (non-condensing)
- Ambient pressure: 450 bar (front side)

- 1) Models with plug connection only with suitable and connected mating plug

## Scope of Supply

- 1 Eddy current long-stroke displacement sensor
- 1 Measuring tube
- 1 Test report
- 1 Assembly instructions

You can find more information about the sensor in the operating instructions. They are available online at

<http://www.micro-epsilon.de/download/manuals/man--induSENSOR-EDS--en.pdf>

## Measuring Principle

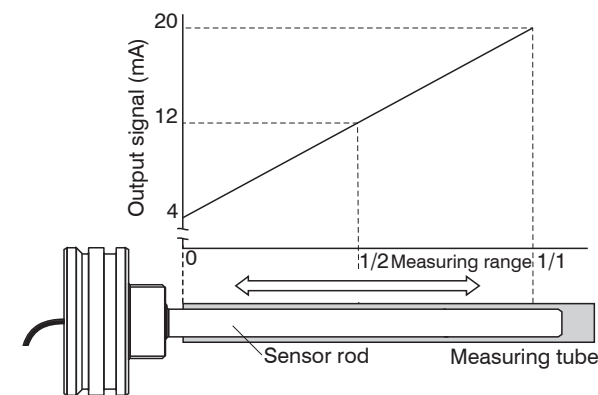

Output characteristic of an eddy current long-stroke displacement sensor.  
Position of measuring tube: Start of measuring range

## Pin Assignment for Power Supply and Analog Output

The 4-pin connector on the hydraulic cylinder ensures power supply and signal output.

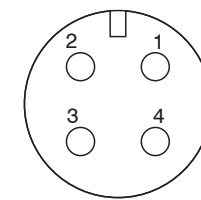

View: Connector pin side, M12 x 1; 4-pin.

Pin	Assignment	Wire color
1	Signal ground	Brown
2	Supply + (18 ... 30 VDC)	White
3	Signal 4 ... 20 mA <sup>1</sup>	Blue
4	Supply ground	Black

Pin assignment for 4-pin plug-in connection, view on solder pin side of cable connector

- 1) Can be converted to voltage output with external load resistor!



Assembly Instructions  
**induSENSOR**  
EDS- ... -Z Series



## Installation and Assembly

### Precautions

The measuring tube must not contact the sensor rod during operation.

> Damage to or destruction of the sensor through abrasion is possible.

Do not deform or shorten the measuring tube.

> Loss of specified technical data

Do not crush the O-ring or damage through sharp-edged items.

> Loss of functionality

### Sensor Mounting

▶ Mount the sensor so that it is held by the back plate and then fix it with a grub screw.

Sealing is provided by an O-ring on the sensor shaft.

▶ Guide the connection braids of the sensor in the cable duct to the outside and connect them with the mounting plug.

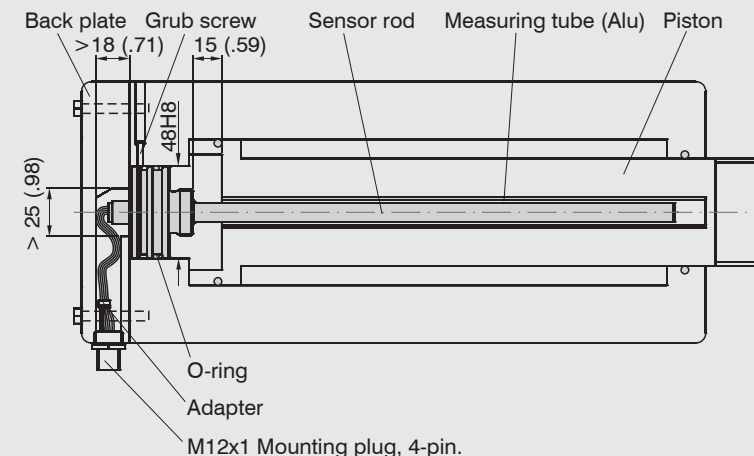

Sensor mounting in a hydraulic cylinder, dimensions in mm (inches)

Pressure chamber seal: <sup>1</sup>

- O-ring: 44.12 x 2.62
- Material: Viton

Mounting hole for flange: Ø48H8

Borehole surface:

- $R_a = 0.8$
- $R_{max} = 3.2$

Dimension	Tolerance
	$\mu\text{m}$
48H8	+39
	0

1) Not included in delivery

### Measuring Tube Guidance and Fastening

▶ Mount the measuring tube flush in the piston bore.

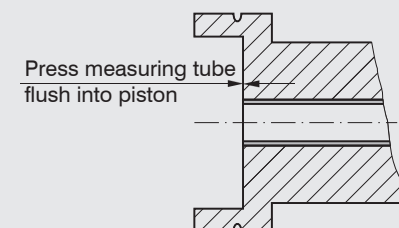

The dimensions for the measuring tube can be found in the adjacent dimensional drawing. The measuring tube must not touch the sensor shaft when the piston is retracted.

Note the measuring tube position at zero point (= 4 mA output).

> Improper measuring tube guidance can lead to increased wear and premature failure.

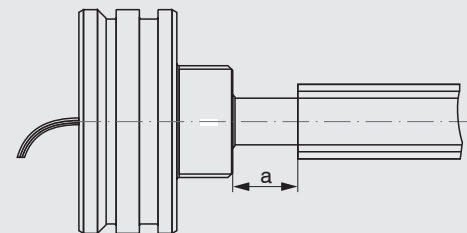

Zero position of the measuring tube

Measuring range	220 (8.66)	260 (10.23)	300 (11.81)	370 (14.57)	400 (15.74)
Dimension a	20 (0.79)	20 (0.79)	20 (0.79)	25 (0.98)	25 (0.98)

A slightly eccentric mounting of the measuring tube has no negative influence on the sensor signal.

▶ Mount the measuring tube in the piston by means of pressing or glueing.

Spot clamping is not permissible.



The specified technical data only apply when the measuring tube supplied by MICRO-EPSILON is used!

### Dimensional Drawing

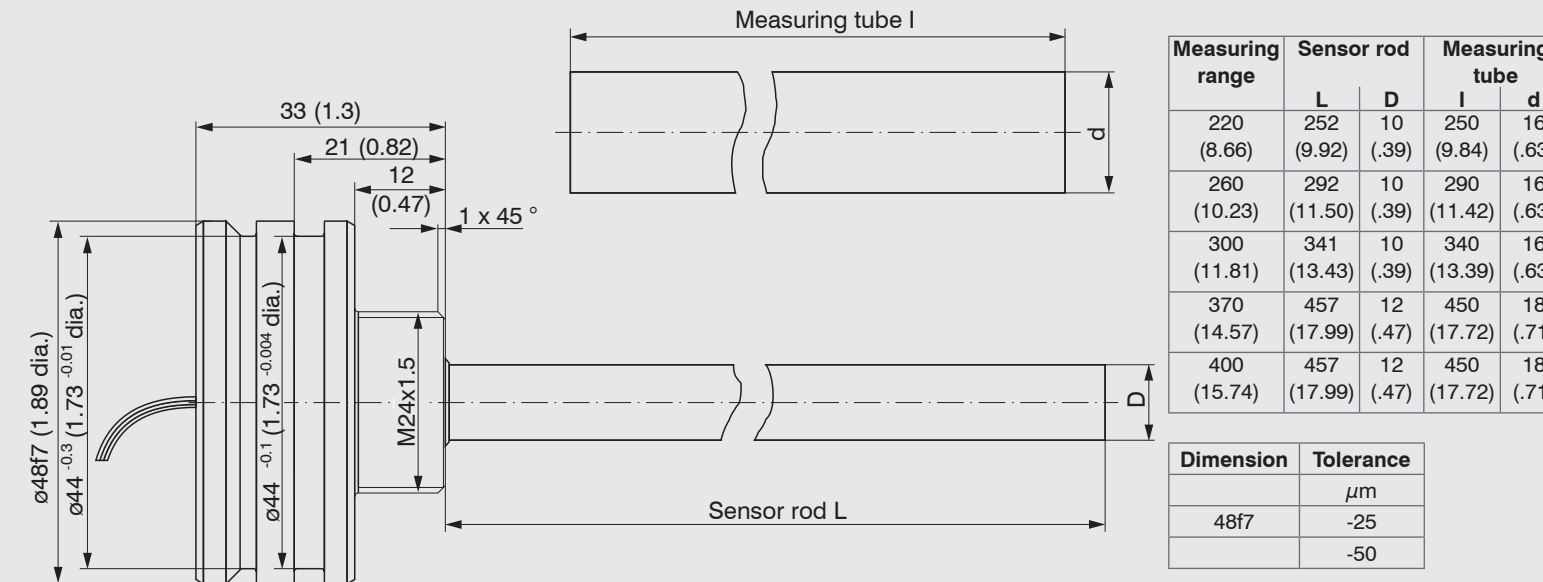

induSENSOR with axial braids, EDS- ... -Z series, measuring range: 220 / 260 / 300 / 370 / 400, dimensions in mm (inches)

Measuring range	Sensor rod		Measuring tube	
	L	D	l	d
220 (8.66)	252 (9.92)	10 (.39)	250 (9.84)	16 (.63)
260 (10.23)	292 (11.50)	10 (.39)	290 (11.42)	16 (.63)
300 (11.81)	341 (13.43)	10 (.39)	340 (13.39)	16 (.63)
370 (14.57)	457 (17.99)	12 (.47)	450 (17.72)	18 (.71)
400 (15.74)	457 (17.99)	12 (.47)	450 (17.72)	18 (.71)

Dimension	Tolerance
	$\mu\text{m}$
48f7	-25
	-50

## Dismantling

▶ Use an extractor tube for dismantling.

Female thread in the extractor tube: M24 x 1.5

Procedure:

1. Open the plug connection on the intermediate plug.

2. Loosen the grub screw.

3. Unscrew the extractor tube on the sensor shaft and pull the sensor out of the cylinder.

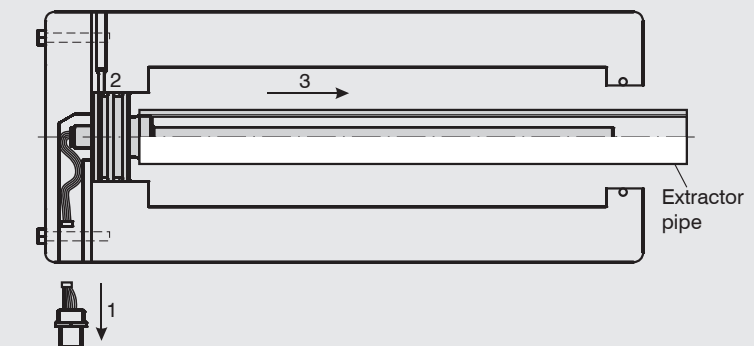

Dismantling an induSENSOR, EDS- ... -Z series

MICRO-EPSILON MESSTECHNIK GmbH & Co. KG

Koenigbacher Str. 15

94496 Ortenburg / Germany

Tel. +49 8542 / 168-0 / Fax +49 8542 / 168-90

e-mail info@micro-epsilon.com

www.micro-epsilon.com

Your local contact: [www.micro-epsilon.com/contact/worldwide/](http://www.micro-epsilon.com/contact/worldwide/)