

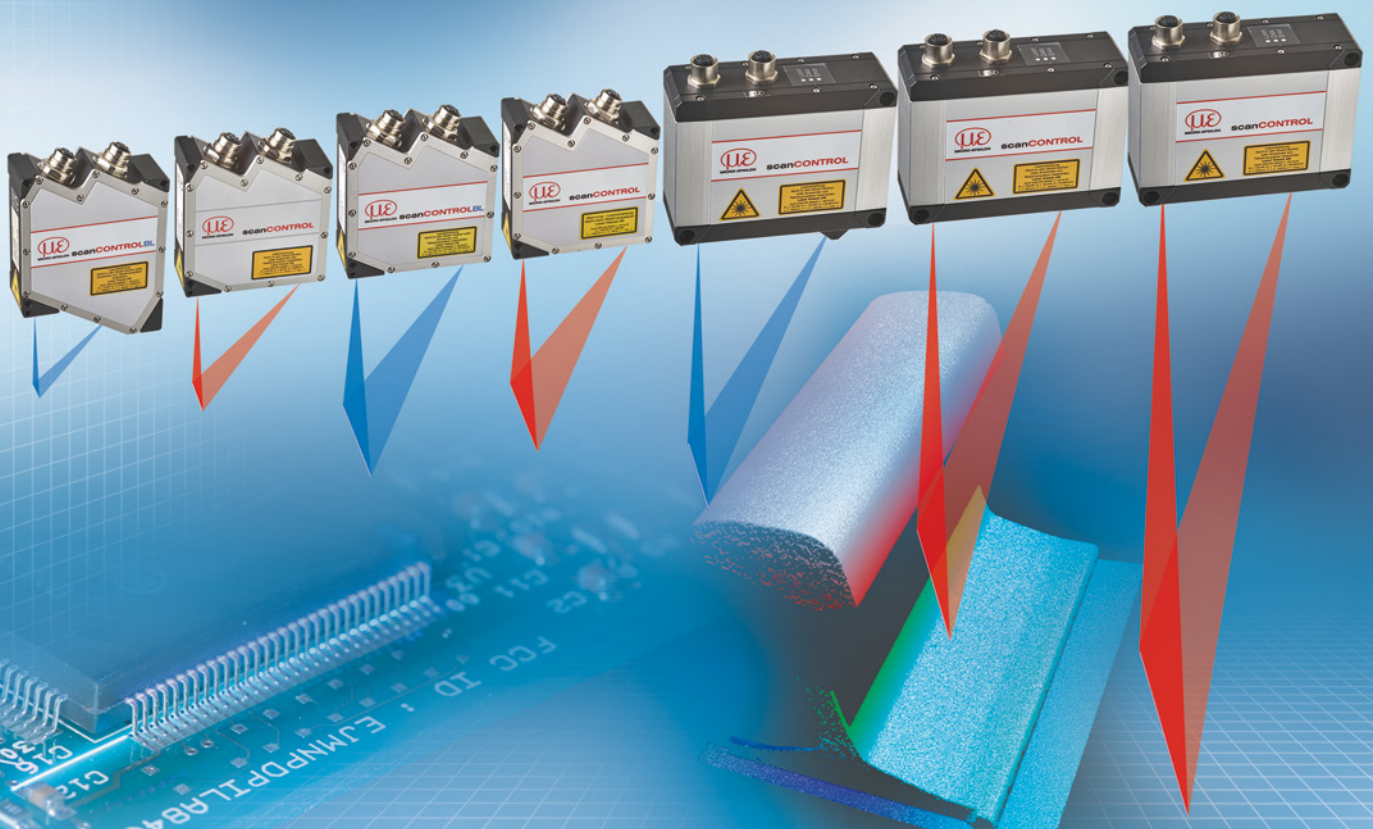

More Precision

scanCONTROL // 2D/3D Laser profile sensors





- Ideal for precise 2D/3D measurements
- Resolution (x-axis) 1,280 points
- High accuracy for the detection of finest details
- Profile frequency up to 2,000 Hz
- Also available with patented Blue Laser Technology

Compact design for precise measurements

scanCONTROL 29x0 laser scanners are designed for industrial measurement tasks where compact design and high accuracy are required. Thanks to their high resolution, versatility and excellent price-performance ratio, the scanners are particularly suitable for static and dynamic applications, e.g., on robots. They measure and evaluate, e.g., angles, steps, gaps, distances and extreme values.

Available as COMPACT and SMART versions

The scanCONTROL 29x0 series is available as COMPACT and SMART versions. The COMPACT scanners provide calibrated profile data that can be further processed on a PC with software evaluation provided by the customer. SMART scanners operate autonomously and provide selected measurement values. The sensor parameters and the desired measuring programs are set in the scanCONTROL Configuration Tools software and directly stored in the internal controller.

Small measuring range with high resolution

With a laser line of just 10 mm, the scanCONTROL 29x0-10/BL models recognize the finest of details and structures. The high profile resolution combined with the blue laser line allow for maximum precision in versatile applications, e.g., monitoring in electronics production.

Article designation

| | | | | |
|-------------------------|----|----|-----|-----|
| LLT | 29 | 00 | -25 | /SI |
| Options - see below | | | | |
| Measuring range | | | | |
| 10 mm (only Blue Laser) | | | | |
| 25 mm | | | | |
| 50 mm | | | | |
| 100 mm | | | | |
| Class | | | | |
| 00=COMPACT | | | | |
| 10=SMART | | | | |
| 50=HIGHSPEED | | | | |
| 60=HIGHSPEED SMART | | | | |
| Series | | | | |
| LLT29x0 | | | | |

Laser options*

| | | |
|--|-----|---|
| | /SI | Hardware switch-off of the laser line |
| | /3B | Increased laser power (class 3B, ≤ 20 mW), e.g., for dark surfaces |
| | /BL | Blue laser line (405 nm) for (semi-) transparent, red-hot glowing and organic materials |

Cable output options*

| | | |
|--|-----|--|
| | /PT | Cable directly out of the sensor ("Pigtail") Length 0.3 m |
| | /VT | Cable directly out of the sensor ("Variable Tail") Length 0.1 ... 1.0 m (freely selectable) |

*Options can be combined

| Model | | LLT29x0-10/BL | LLT 29xx-25 | LLT 29xx-50 | LLT 29xx-100 | |
|---|-----------------------------------|--|--|----------------------|----------------------|-------------------|
| Available laser type | | Blue Laser | Red Laser Blue Laser | Red Laser Blue Laser | Red Laser Blue Laser | |
| z-axis | Measuring range | Start of measuring range | 52.5 mm | 53.5 mm | 70 mm | 190 mm |
| | | Mid of measuring range | 56.5 mm | 66 mm | 95 mm | 240 mm |
| | | End of measuring range | 60.5 mm | 78.5 mm | 120 mm | 290 mm |
| | | Height of measuring range | 8 mm | 25 mm | 50 mm | 100 mm |
| | Extended measuring range | Start of measuring range | - | 53 mm | 65 mm | 125 mm |
| | | End of measuring range | - | 79 mm | 125 mm | 390 mm |
| | Line linearity ¹⁾²⁾ | | 1 μm ±0.0125 % | 2 μm ±0.008 % | 4 μm ±0.008 % | 12 μm ±0.012 % |
| x-axis | Measuring range | Start of measuring range | 9.4 mm | 23.4 mm | 42 mm | 83.1 mm |
| | | Mid of measuring range | 10 mm | 25 mm | 50 mm | 100 mm |
| | | End of measuring range | 10.7 mm | 29.1 mm | 58 mm | 120.8 mm |
| | Extended measuring range | Start of measuring range | - | 23.2 mm | 40 mm | 58.5 mm |
| | | End of measuring range | - | 29.3 mm | 60 mm | 143.5 mm |
| Resolution | | 1,280 points/profile | | | | |
| Profile frequency | Standard | up to 300 Hz | | | | |
| | Highspeed | up to 2,000 Hz | | | | |
| Interfaces | Ethernet GigE Vision | Output of measurement values Sensor control Profile data transmission | | | | |
| | Digital inputs | Mode switching Encoder (counter) Trigger | | | | |
| | RS422 (half-duplex) ³⁾ | Output of measurement values Sensor control Trigger Synchronization | | | | |
| Output of measurement values | | Ethernet (UDP / Modbus TCP); RS422 (ASCII / Modbus RTU) analog ⁴⁾ ; switch signal ⁴⁾ PROFINET ⁵⁾ ; EtherCAT ⁵⁾ ; EtherNet/IP ⁵⁾ | | | | |
| Control and display elements | | 3x color LEDs for laser, data and error | | | | |
| Light source | | - | ≤ 8 mW | | | |
| | Red Laser | - | Standard: laser class 2M, semiconductor laser 658 nm | | | |
| | | - | ≤ 20 mW | | | |
| | Blue Laser | - | Option: laser class 3B, semiconductor laser 658 nm | | | |
| | Laser switch-off | ≤ 8 mW Standard: laser class 2M, semiconductor laser 405 nm | | | | |
| Aperture angle of laser line | | 10° | 20° | 25° | 25° | |
| Permissible ambient light (fluorescent light) ¹⁾ | | 10,000 lx | | | | |
| Protection class (DIN EN 60529) | | IP65 (when connected) | | | | |
| Vibration (DIN EN 60068-2-27) | | 2 g / 20 ... 500 Hz | | | | |
| Shock (DIN EN 60068-2-6) | | 15 g / 6 ms | | | | |
| Temperature range | Storage | -20 ... +70 °C | | | | |
| | Operation | 0 ... +45 °C | | | | |
| Weight | | 440 g (without cable) | 380 g (without cable) | | | |
| Supply voltage | | 11 ... 30 VDC, nominal value 24 V, 500 mA, IEEE 802.3af class 2, Power over Ethernet (PoE) | | | | |

¹⁾ According to measuring range; Measuring object: Micro-Epsilon standard object

²⁾ According to a one-time averaging over the width of the measuring field (640 points)

³⁾ RS422 interface, programmable either as serial interface or as input for triggering/synchronization

⁴⁾ Only with 2D/3D Output Unit

⁵⁾ Only with 2D/3D Gateway

LLT29x0-10/BL

Blue Laser

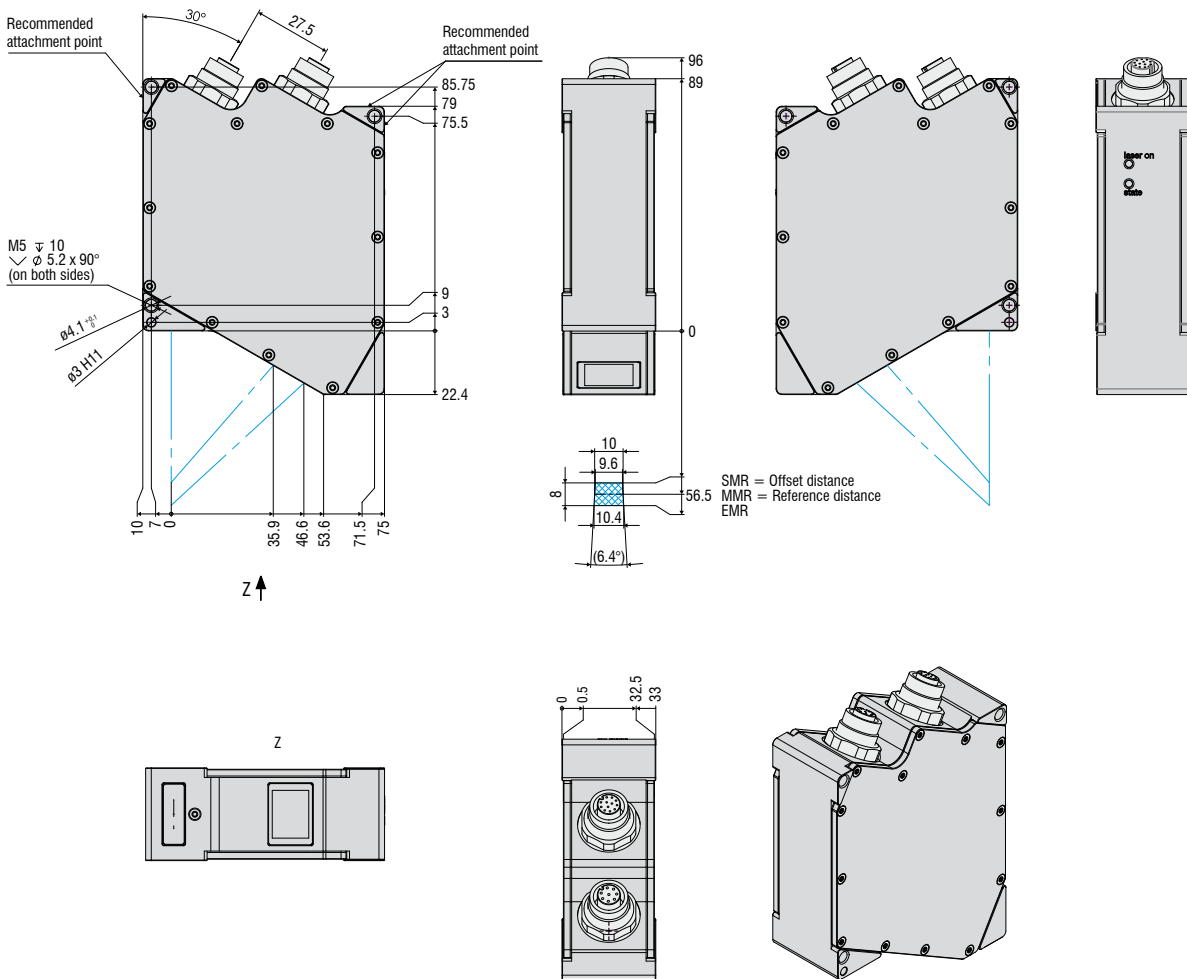

LLT25x0-25 / LLT29x0-25

Red Laser Blue Laser

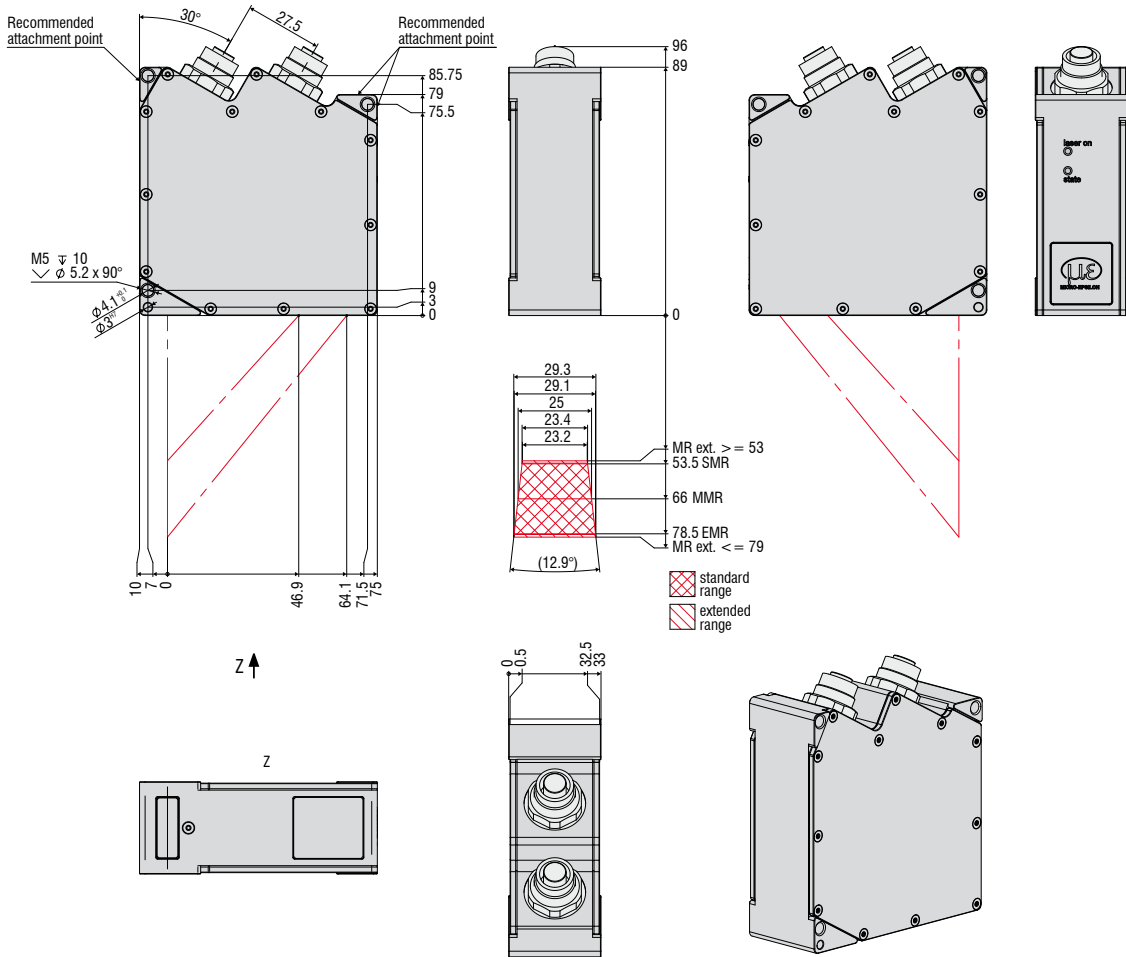

LLT25x0-50 / LLT29x0-50

Red Laser

Blue Laser

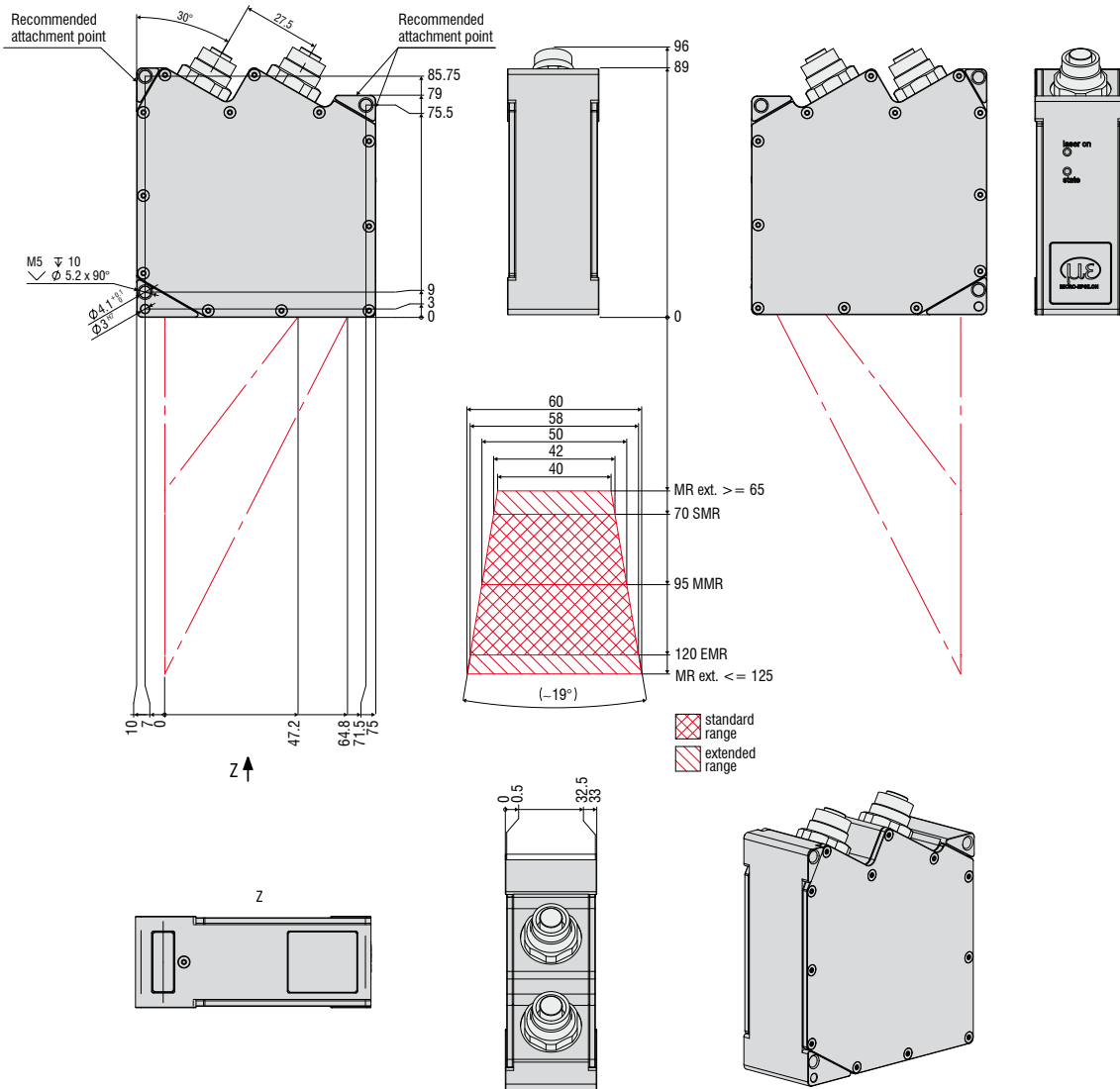

LLT25x0 / LLT29x0-100

Red Laser Blue Laser

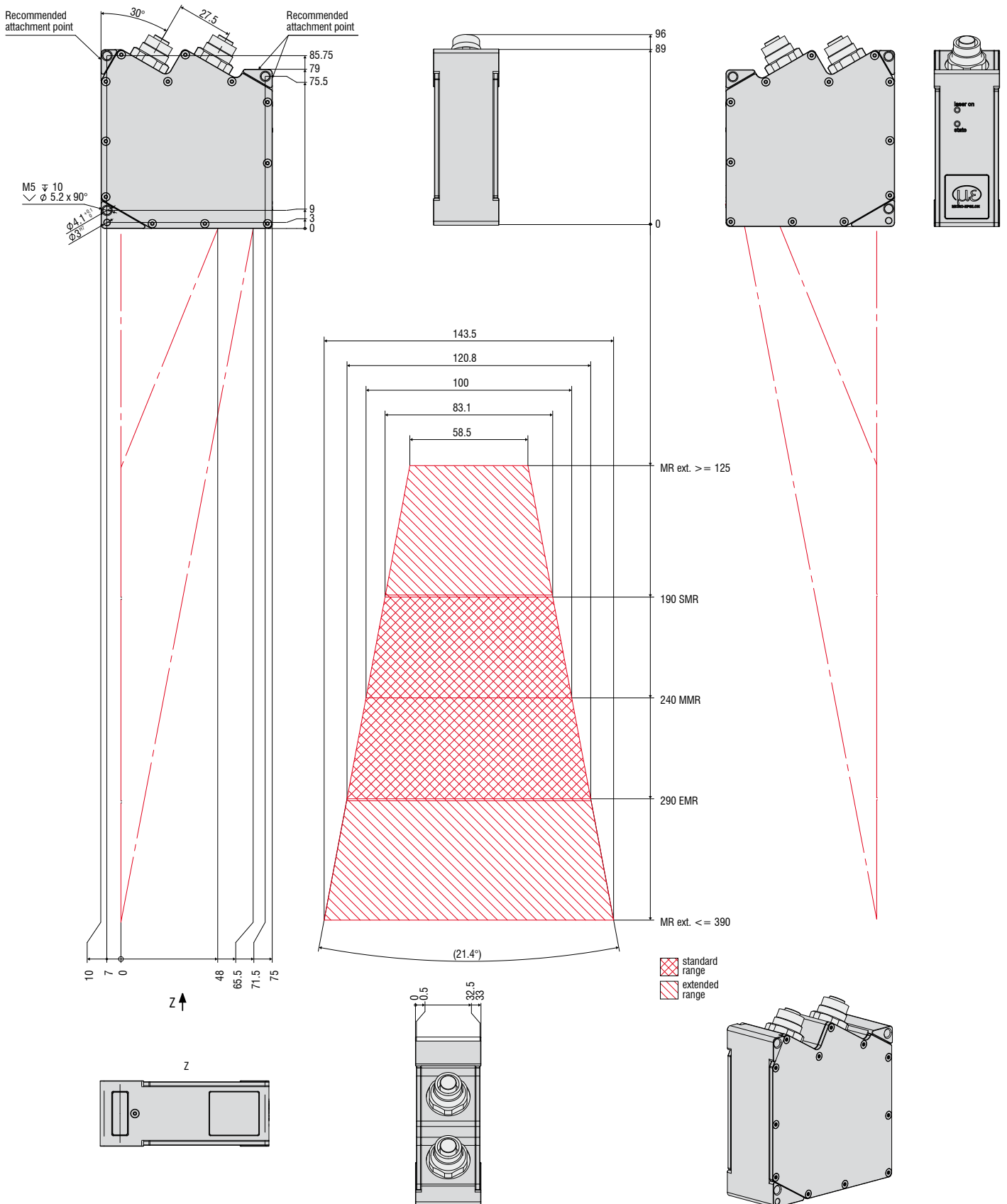

Sensors and Systems from Micro-Epsilon

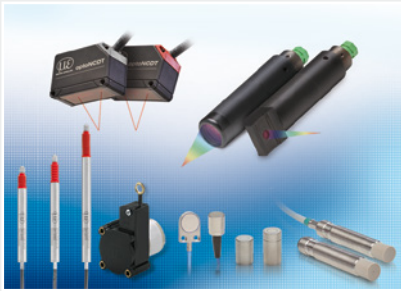

Sensors and systems for displacement, position and dimension



Sensors and measurement devices for non-contact temperature measurement



Measuring and inspection systems for quality assurance

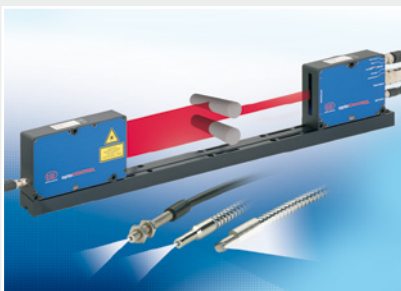

Optical micrometers, fiber optics, measuring and test amplifiers



Color recognition sensors, LED Analyzers and inline color spectrometers



3D measurement technology for dimensional testing and surface inspection

